

 **OMEGA**<sup>®</sup>  
FOODTECH



**GI 350 - GI 370**



- 

**AFFETTATRICE A GRAVITÀ**  
Costruita in lega di alluminio trattata con ossidazione anodica.  
Trasmissione ad ingranaggi.  
Affilatoio incorporato.  
Per il dettaglio, i supermercati e la ristorazione collettiva.  
Macchine conformi alle norme **CE** in materia di igiene e di sicurezza.  
Comandi con dispositivo N.V.R.
- 

**GRAVITY SLICING MACHINE**  
Made of aluminium alloy treated with anodic oxidation.  
Gear drive.  
Built-in sharpener.  
For retail, supermarkets and collective catering.  
The machines complies with **CE** standards in terms of hygiene and safety.  
Controls with N.V.R. device.
- 

**SCHWERKRAFT-AUFSCHNITTMASCHINE**  
Ausgeführt aus Aluminiumlegierung, poliert und eloxiert.  
Zahngetriebe.  
Eingebaute Schleifvorrichtung.  
Für Lebensmitteleinzelhandel, Supermärkte und Großgastronomie.  
Maschinen mit den **CE**-Normen in bezug auf Hygiene und Sicherheit konform.  
Ein-Aus Drucktaste.
- 

**TRANCHEUSE À GRAVITÉ**  
Réalisée en alliage d'aluminium traité par oxydation anodique.  
Transmission à engrenages.  
Aiguiseur incorporé.  
Pour le détail, les supermarchés et la restauration collective.  
Machines conformes aux normes **CE** en matière d'hygiène et sécurité.  
Boutons Marche-Arrêt.
- 

**CORTADORA DE FIAMBRES A GRAVEDAD**  
Costruida en aleación de aluminio tratada con oxidación anódica.  
Transmisión a engranajes.  
Afilador incorporado.  
Para venta minorista, supermercados y restauración colectiva.  
Máquinas conformes a lo establecido por las normativas **CE** en materia de higiene y de seguridad.  
Mandos con dispositivo N.V.R.

## Specifiche tecniche / Technical specifications

|   | GI 350              | GI 370              |
|---|---------------------|---------------------|
| diametro lama, diameter of the blade, Klingedurchmesser, diametre de la lame, diametro de la cuchilla | 350 mm              | 370 mm              |
| motore, motor, Motor, moteur, motor   | 0,37 (0,50) kW (HP) | 0,37 (0,50) kW (HP) |
| corsa carrello, carriage stroke, Schilliten weglauf, course du chariot, carrera del carro             | 340 mm              | 340 mm              |
| ampiezza taglio, cut, Schnittgröße, ampleur de coupe, amplitud de corte $\emptyset$                   | 260 mm              | 270 mm              |
| ampiezza taglio, cut, Schnittgröße, ampleur de coupe, amplitud de corte $\sphericalangle$             | 220 x 270 mm        | 230 x 270 mm        |
| spessore taglio, cut thickness, Schnittstärke, epaisseur de coupe, espesor de corte                   | 0/22 mm             | 0/22 mm             |
| peso netto, net weight, Nettogewicht, poids net, peso neto  | 48 kg               | 49 kg               |

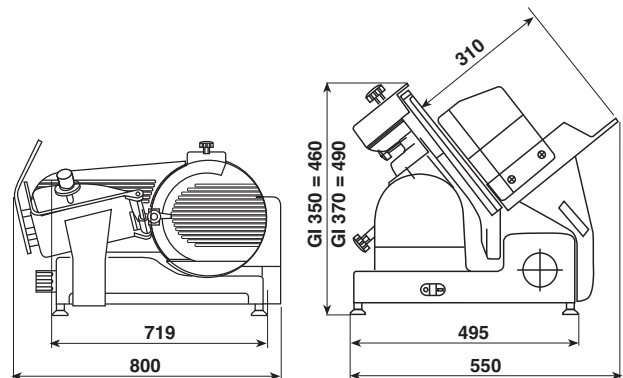

Nota: i dati del presente catalogo non sono impegnativi e potranno subire variazioni senza preavviso / Specifications and other features are subject to change without notice (02/13)