

# HAMBURGATRICI MANUALI

## MANUAL MEAT PRESSES



C/94



C/95F - C/95G

## HAMBURGATRICI MANUALI

- Per formare in modo semplice e veloce ottimi hamburger tondi e compatti. Possono essere usate combinazioni di vari ingredienti: carni di manzo o pesce, pangrattato, uova, spezie, verdure
- Struttura in alluminio anodizzato e piattelli in acciaio inox AISI 304
- Facili da pulire
- Forniti con una confezione di cellophane per alimenti
- Per macellerie, fast food, gastronomie, supermercati, ristorazione collettiva

## MANUAL MEAT PRESSES

- A fast and simple way to form excellent round, compact burgers. Various combinations of ingredients may be used: beef or fish, breadcrumbs, eggs, spices, vegetables
- Anodised aluminium structure and AISI 304 stainless steel plates
- Easy to clean
- Supplied with a package of cellophane food wrap
- For butcher's shops, fast food restaurants, delicatessens, supermarkets, food-packing centres, canteens and catering services

## RECONSTITUEUR MANUEL

- Pour préparer de manière simple et rapide d'excellents steaks hâchés, ronds et compacts. Peuvent être utilisés en combinant différents ingrédients: viandes de boeuf ou poisson, chapelure, oeufs, épices
- Structure en aluminium anodisé et plaques en acier inox AISI 304.
- Faciles à nettoyer
- Fournis avec emballage cellophane à usage alimentaire
- Pour les boucheries, les fast-foods, les traiteurs, la grande distribution, les centres de conditionnement, la restauration collective

## MANUELLE FLEISCHPRESSE

- Einfaches und schnelles Formen von ausgezeichneten, runden und kompakten Hamburgern. Es können Kombinationen verschiedener Zutaten verwendet werden: Rindfleisch oder Fisch, Paniermehl, Eier, Gewürz, Gemüse
- Struktur aus eloxiertem Aluminium und Teller aus Edelstahl AISI 304
- Einfache Reinigung
- Geliefert mit einer lebensmittelechten Zellophan - Verpackung
- Für Metzgereien, Fast-Food-Restaurants, Gastgewerbe, Supermärkte, Verpackungszentren, Gemeinschaftsverpflegung

## HAMBURGUESADORAS MANUALES

- Para formar de manera simple y rápida óptimas hamburguesas redondas y compactas. Pueden usarse combinaciones de diferentes ingredientes: carnes de ternera o pescado, pan rallado, huevos, especias
- Estructura de aluminio anodizado y platillos de acero inox AISI 304
- Fáciles de limpiar
- Suministrados con un porta celofán para alimentos
- Para carnicerías, fast food, tiendas de gastronomía, supermercados, centros de envasado, comedores colectivos



C/95H

## CARATTERISTICHE TECNICHE - TECHNICAL SPECIFICATIONS - TECHNISCHE DATEN - CARACTERISTIQUES - ESPECIFICACIONES

		C/94	C/95F	C/95G	C/95H
Peso netto - Net weight - Poids net - Nettogewicht - Peso neto	kg	5,1	5,7	5,8	7,7
<b>HAMBURGER</b>					
Forma - Shape - Moule - Form - Forma	Ø mm	100	130	150	180
	g	120	200	265	360

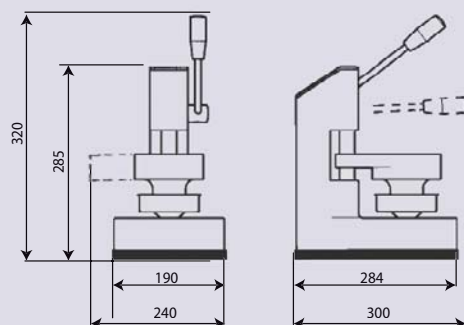

C/94

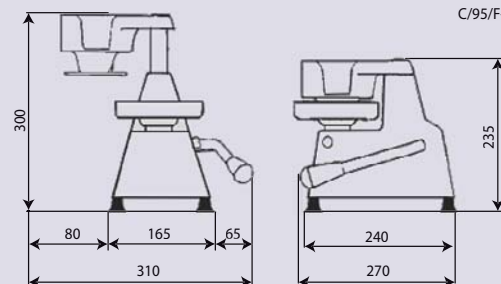

C/95F-C/95G

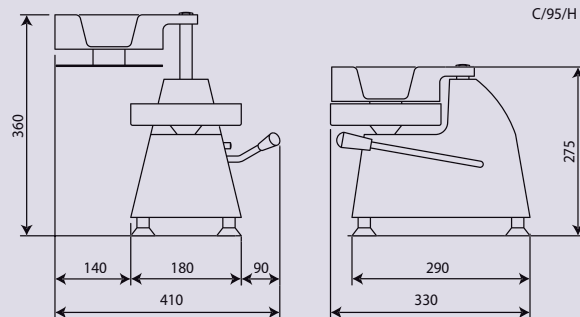

C/95/H